

Description of *Scriptaphyosemion wieseae* (Cyprinodontiformes: Nothobranchiidae), a new species from northern Sierra Leone

Rainer Sonnenberg^{1,2} & Eckhard Busch³

¹ Zoologisches Forschungsmuseum Alexander Koenig, Adenauerallee 160, D-53113 Bonn, Germany

² Max-Planck-Institut für Evolutionsbiologie, Department of Evolutionary Genetics, August-Thienemann-Strasse 2, D-24306 Plön, Germany. Corresponding author. E-mail: r.sonnenberg.zfmk@uni-bonn.de

³ Diederichsstrasse 45, D-42855 Remscheid, Germany.

Abstract. *Scriptaphyosemion wieseae*, new species, is described from collections in northern Sierra Leone. Results of a small DNA study indicate, that *S. bertholdi* from the southeastern part of the country is the closest relative. Both species can be distinguished by male and female color pattern and male caudal fin shape.

Résumé. *Scriptaphyosemion wieseae*, une nouvelle espèce, est décrite du Nord de la République de Sierra Leone. Le résultat d'une petite étude moléculaire ADN montre que son espèce sœur est *S. bertholdi*, présente au Sud-Est du pays. Les deux espèces se distinguent par les couleurs du mâle et de la femelle et par la forme de la nageoire caudale du mâle.

Key words. Upper Guinean ichthyofaunal province, taxonomy, DNA, phylogeny.

INTRODUCTION

The West African killifish genus *Scriptaphyosemion* Radda & Pürzl, 1987 is relatively species rich, compared to the closely related genera *Archiaphyosemion* Radda, 1977, *Callopanchax* Myers, 1933, and *Nimbapanchax* Sonnenberg & Busch, 2009. At present 18 specific names are available in *Scriptaphyosemion* (Eschmeyer 2011; Huber 2007; Lazara 2001), but only 10 (Huber 2007; Wildekamp & Van der Zee 2003) to 13 (Costa 2008; Lazara 2001) species are currently accepted as valid, depending on author and concept (Huber 2007; Eschmeyer 2011; Lazara 2001; Scheel 1990; Wildekamp 1993). Among the West African killifish genera, species number in *Scriptaphyosemion* is only exceeded by the Upper Guinean species of the related genus *Epiplatys* Gill, 1862 (Costa 2008; Huber 2007; Wildekamp & Van der Zee 2003).

In nothobranchiid killifishes, most species are diagnosed by male color pattern (Amiet 1987; Sonnenberg 2007), which is, however, increasingly supplemented by molecular approaches (e.g. Agnèse et al. 2009; Legros et al. 2005; Legros & Zentz 2007a, b; Sonnenberg 2007, 2008; Sonnenberg & Blum 2005; Sonnenberg & Busch 2009, 2010; Sonnenberg et al. 2006, 2011; Van der Zee & Sonnenberg 2011). In *Scriptaphyosemion*, female color pattern has also been used as character for diagnosing species or groups of species (Roloff 1971a).

In most species of *Scriptaphyosemion*, interspecific variance in male color pattern is accompanied by intraspecific variance between and within populations, a phenome-

non which may confuse species identification; however, some of the most variable species might be composed of more than one species (see e.g. figures or drawings in Seegers 1997; Wildekamp 1993). This combination of intraspecific variability, inclusion of probably different species under one taxon, and the lack of a specific diagnosis in many species descriptions contributed to some confusion in *Scriptaphyosemion* taxonomy (see e.g. Scheel 1990). More than a decade ago, Murphy et al. (1999) published the first molecular genetic phylogeny of *Scriptaphyosemion*, based on the sequences of the partial cytochrome b and 12S rRNA genes and including eleven species. This phylogeny gave a first insight into the relationships and an additional set of independent characters for further taxonomic and phylogenetic research.

Species diversity of *Scriptaphyosemion* is highest in Sierra Leone, Liberia, and Guinea. However, the distribution area also includes Burkina Faso, Gambia, Guinea-Bissau, Ivory Coast, Mali, and Senegal (Huber 2007; Paugy et al. 1990; Teugels et al. 1988; Wildekamp 1993; Wildekamp & Van der Zee 2003). In Sierra Leone, *Scriptaphyosemion* species are mainly known from the coastal lowland, the northern and eastern killifish fauna is only little known (Etzel 1977, 1978a, b, 1984; Huber 2007; Wildekamp 1993; Wildekamp & Van der Zee 2003).

In 1993, the second author collected together with B. Wiese nothobranchiids in the northern part of Sierra Leone (Busch 1995a), including a probably new species near

Table 1. List of specimens used for the DNA analyses with locality data and GenBank accession numbers (ND2+tRNAs, mtLSU rDNA, nLSU rDNA). * Sequences published in Sonnenberg & Busch (2009).

Species	sample	Country	Collection locality	GenBank acc. no.
<i>Epiplatys sexfasciatus</i>	RS1364	Gabon	G 02/91	JX124276, FJ872035*, FJ872049*
<i>Scriptaphyosemion bertholdi</i>	RS1402	Sierra Leone	SL 93/51	JX124261, JX124233, JX124247
<i>S. brueningi</i>	RS1377	Sierra Leone	SL 03/04	JX124262, JX124234, JX124248
<i>S. brueningi</i>	RS1403	Sierra Leone	SL 89, Perie	JX124263, JX124235, JX124249
<i>S. cauveti</i>	RS1680	Guinea	GM 97/05	JX124264, JX124236, JX124250
<i>S. chaytori</i>	RS1379	Sierra Leone	SL 93/23 Ngabu	JX124265, JX124237, JX124251
<i>S. fredrodi</i>	RS1398	Sierra Leone	SL 89, Matanga	JX124266, JX124238, JX124252
<i>S. geryi</i>	RS1381	Sierra Leone	SL 03/09, Robis 1	JX124267, FJ872033*, FJ872047*
<i>S. guignardi</i>	RS1380	Guinea	GM 97/13	JX124268, JX124239, JX124253
<i>S. liberiense</i>	RS1757	Liberia	L 97	JX124269, JX124240, JX124254
<i>S. roloffii</i>	RS1376	Sierra Leone	SL 03/10	JX124270, JX124241, JX124255
<i>S. schmitti</i>	RS1755	Liberia	RL 83/121	JX124271, JX124242, JX124256
<i>S. sp.</i>	RS1378	Sierra Leone	SL 03/18	JX124272, JX124243, JX124257
<i>S. wieseae</i>	RS1382	Sierra Leone	SL 03/16	JX124273, JX124244, JX124258
<i>S. wieseae</i>	RS1686	Sierra Leone	SL 03/15	JX124274, JX124245, JX124259
<i>S. wieseae</i>	RS1687	Sierra Leone	SL 03/17	JX124275, JX124246, JX124260

Lenghe Curoh. In 2003 they revisited this locality and found two additional collection localities of this species (Fig. 1). Preliminary crossing experiments by engaged aquarists (Vandersmissen 2003) indicated its probable incompatibility with *S. bertholdi* (Roloff, 1965), which was considered to be the potentially closest relative. Here, we provide a formal species description and present the phylogenetic position of the new species within *Scriptaphyosemion*, based on mitochondrial and nuclear DNA sequences.

MATERIAL AND METHODS

The species description is based on collections made in Sierra Leone by the second author and B. Wiese during their second visit in this area in November 2003. Specimens were deposited in the Royal Museum for Central Africa (MRAC, Tervuren, Belgium), the Zoologische Staatssammlung München (ZSM, Munich, Germany), and the Zoologisches Forschungsmuseum Alexander Koenig (ZFMK, Bonn, Germany).

For counts and measurements, see Sonnenberg & Busch (2009, 2010). All measurements were taken with a digital caliper, partly under a dissecting microscope, to the nearest 0.1 mm. Measurements, including those of the head, are presented as percentages of standard length (SL). The head region of one specimen was scanned with a Scanco viva CT40 at the Max-Planck-Institut für Evolutionsbiologie in Plön, digital X-ray images were made with a Faxitron LX-60 Digital Specimen Radiography System at the ZFMK. Fin rays of unpaired fins were counted on digital X-ray images; the relative position of the first dorsal fin ray to the anal fin (D/A) is estimated following Sonnenberg & Schunke (2010). Nomenclature of the neuro-mast system on the head follows Scheel (1968), for supra-orbital (or frontal) squamation Hoedeman (1958). Male and female color patterns are compared with that given in the respective description and on pictures or drawings published in the literature.

As species concept we employ the pragmatic approach of Moritz et al. (2000) and recognize species by diagnostic combinations of characters.

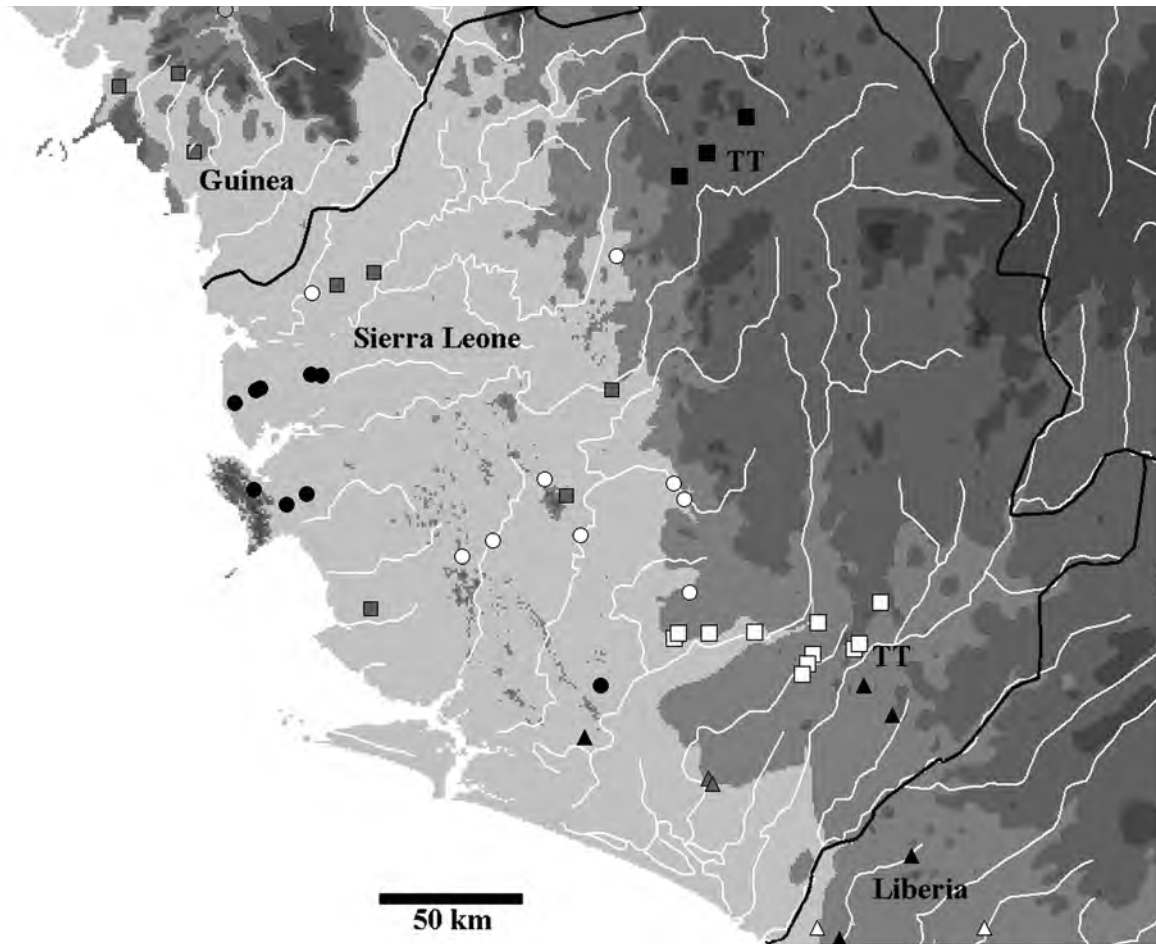

Fig. 1. Distribution map of *Scriptaphyosemion* in Sierra Leone based on data from Huber (2007) and own data of the second author. White square: *S. bertholdi*; black triangle: *S. brueningi*; white circle: *S. chaytori*; dark grey triangle: *S. fredrodi*; dark grey square: *S. geryi*; light grey circle: *S. guignardi*; white triangle: *S. liberiense*; black circle: *S. roloffii*; black square: *S. wieseae*. TT marks the type localities of *S. bertholdi* and *S. wieseae*.

A DNA dataset was prepared for 15 *Scriptaphyosemion* specimens, including 11 species, and *Epiplatys sexfasciatus* Gill, 1862 as outgroup. We sequenced the complete mitochondrial ND2 gene and adjacent tRNAs, and fragments of the mitochondrial and nuclear LSU rDNA genes. Parts of the sequences were published in earlier papers of the authors; all samples are listed with GenBank accession numbers and collection locality in Table 1. For details on the DNA methods, see Sonnenberg & Busch (2009, 2010) and Sonnenberg et al. (2007).

Abbreviations used in Table 2 and Figures 2–3: BER = *S. bertholdi*, BRU = *S. brueningi* (Roloff, 1971b), CAU = *S. cauveti* (Romand & Ozouf, 1995), CHY = *S. chaytori* (Roloff, 1971a), FRE = *S. fredrodi* (Vandersmissen et al., 1980), GER = *S. geryi* (Lambert, 1958), GUI = *S. guignardi* (Romand, 1981), LIB = *S. liberiense* (Boulenger, 1908), ROL = *S. roloffii* (Roloff, 1936), SMI = *S. schmitti* (Romand, 1979), Ssp = *S. sp.* SL 03/18, WIE = *S. wieseae*, new species, SEX = *E. sexfasciatus*.

Sequences were aligned with ClustalX 1.8 (Thompson et al. 1997), checked by eye, and merged in a single alignment in BioEdit 7.0.5.3 (Hall 1999). As the ND2 sequences of three species are not complete, missing sites were filled with N [*S. liberiense* (560 bp), *S. schmitti* (616 bp), and *S. cauveti* (58 bp)].

The protein coding gene was translated into the corresponding amino acid sequence to check for a functional coding sequence, and base composition of mitochondrial sequences was estimated with MEGA 4.1 beta (Tamura et al. 2007). Uncorrected p-distances with pairwise exclusion of missing data were calculated in MEGA 4.1 beta (Tamura et al. 2007). Number of constant, variable, and informative characters were estimated with PAUP 4.0b10 (Swofford 1998).

Data were analyzed using a maximum parsimony (MP) and a Bayesian approach (BA). Maximum parsimony analyses were performed with PAUP 4.0b10 (Swofford 1998) with the exclusion of uninformative positions and

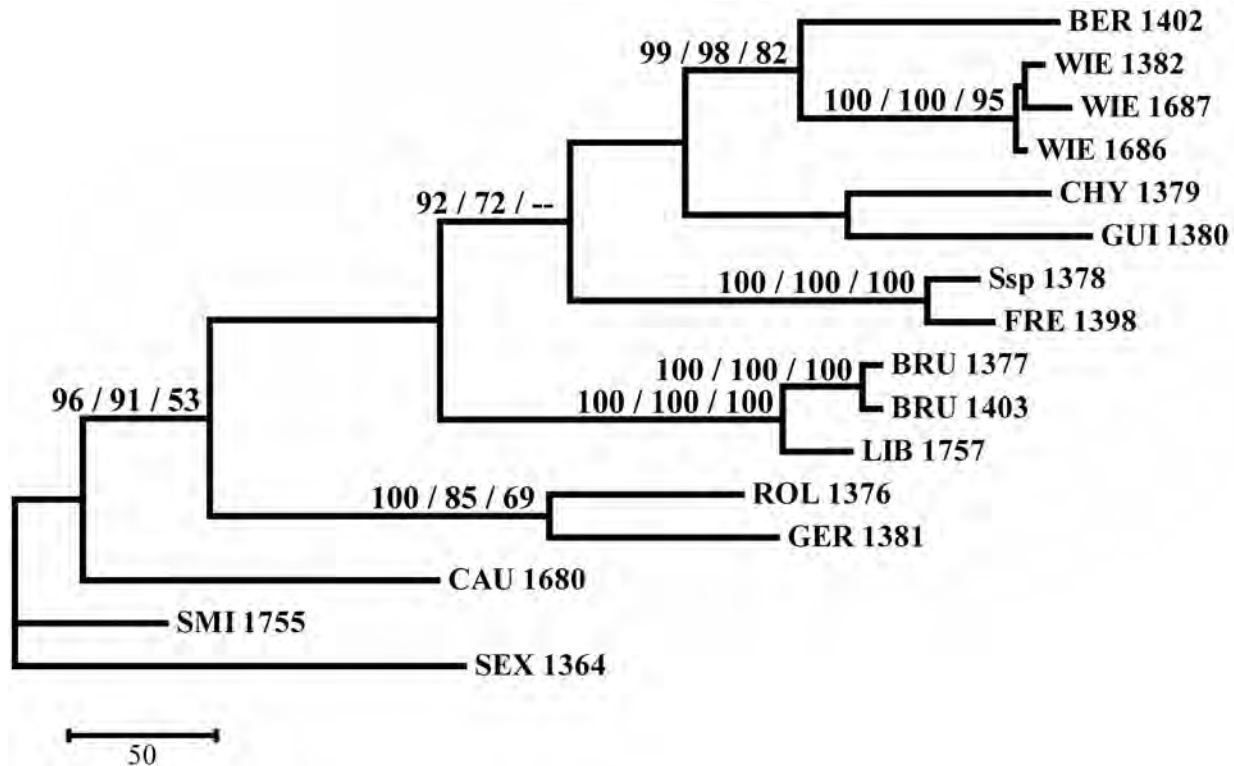

Fig. 2. Results of the maximum parsimony analyses. Shown is one out of three equally short trees from the analysis with the complete dataset. Values left to nodes are the corresponding bootstrap values of all three analyses (complete dataset / third protein coding position excluded / alignment columns with missing data excluded). Values for nodes were only given, if at least one analysis has a bootstrap support above 75 %. Tree length = 1262, consistency index (CI) = 0.5166, homoplasy index (HI) = 0.4834, retention index (RI) = 0.5570, rescaled consistency index (RC) = 0.2878.

gaps coded as fifth character, heuristic tree searches were performed with random addition of sequences for 1,000 replicates. Bootstrap tests were performed with random addition of sequences for 100 replicates and 10,000 bootstrap replicates. Three different analyses were made, one with the complete dataset, one with the exclusion of third protein coding positions, and a third with exclusion of regions, in which one of the above listed specimens has missing data. Otherwise, all parameters were identical.

Bayesian analyses were performed with MrBayes 3.1.2 (Huelsenbeck & Ronquist 2001), data were partitioned in mitochondrial non protein coding regions (tRNA, mtLSU), protein coding regions (ND2), and the nuclear LSU sequences. Number of generation was set to 10,000,000 with sampling of every 1,000 generations and the results of the first 10% of the generations were discarded as burn-in time after checking that the runs had reached the stationary phase at this point. Four analyses were performed: the two alignments, one with the complete data set and one with the exclusion of regions, in which one of the above mentioned specimens has missing data, were both performed with NST=2 and NST=6.

All trees were rooted with *Epiplatys sexfasciatus* as outgroup. Only nodes with bootstrap support values $\geq 75\%$ or posterior probabilities ≥ 0.95 were considered as supported by the data. Nodes below these values were considered as unsupported by the data and not resolved.

RESULTS

DNA Analysis. (Figs 2–3, Table 2). The complete alignment of the ND2, tRNA, and both LSU sequences has a length of 3199 bp including alignment introduced gaps for a total of 16 specimens (503 bp tRNAs, 1047 bp ND2, 481 bp mtLSU rDNA, 1168 bp nLSU rDNA). Of these, 2278 bp are constant, 456 bp variable but uninformative, and 465 bp parsimony informative. The ND2 sequence translates into 349 amino acids with no unexpected stop codon, the base composition of all mitochondrial genes shows the typical base composition for this organelle genome with an anti-G bias (Zhang & Hewitt 1996). Average uncorrected pairwise distance for all sequences is 7.4 %, maximum observed distance for all sequences is 16.6 % between outgroup and ingroup specimens, maximum observed distance between ingroup specimens is 9.0 %, further details are given in Table 2.

Table 2. Uncorrected p-distances with pairwise exclusion of missing data for the complete dataset / the mitochondrial ND2+tRNAs / the mitochondrial LSU rDNA / the nuclear LSU rDNA.

sample	BER1401	BRUI377	BRUI403	CAU1680	CAY1379	FRE1398	GER1381	GUI1380	LIB1757	ROL1376	SMI1755	Ssp1378	WIE1382	WIE1686	WIE1687	SEX1364
BRUI377		6.3/ 11.3/ 2.7/ 0.9														
BRUI403		6.2/ 11.0/ 0.4/ 0.9/ 2.7/ 0.9 0.0/ 0.0														
CAU1680		8.3/ 14.5/ 8.2/ 14.6/ 3.6/ 2.0 3.8/ 1.6 3.8/ 1.6	8.2/ 14.4/													
CAY1379		5.2/ 8.2/ 7.2/ 12.5/ 2.5/ 2.0 3.6/ 1.4 4.6/ 2.8	7.0/ 12.2/ 8.6/ 14.2/													
FRE1398		5.3/ 8.9/ 6.8/ 12.1/ 3.4/ 1.3 3.4/ 0.9 4.0/ 1.8 4.6/ 1.3	6.6/ 11.7/ 8.6/ 15.1/	6.1/ 9.9/												
GER1381		7.5/ 12.4/ 7.9/ 13.4/ 3.6/ 2.3 4.2/ 1.9 4.2/ 1.9 3.8/ 2.5 4.0/ 2.3	7.7/ 13.0/ 9.0/ 15.5/	7.7/ 12.8/	8.2/ 13.8/											
GUI1380		5.9/ 9.7/ 7.5/ 13.0/ 3.4/ 1.7 4.6/ 1.3 4.6/ 1.3 4.2/ 2.1 3.8/ 2.0	7.4/ 12.8/ 8.7/ 15.1/	6.2/ 9.9/	6.6/ 10.9/ 8.3/ 13.8/											
LIB1757		5.6/ 11.4/ 2.1/ 4.4/ 3.6/ 1.4 1.1/ 0.5 1.1/ 0.5 4.9/ 1.7 4.4/ 1.5	2.1/ 4.3/ 7.1/ 14.8/	6.4/ 12.8/	5.6/ 11.8/ 6.5/ 12.8/ 6.5/ 12.9/	5.1/ 1.4 4.4/ 2.2										
ROL1376		6.6/ 11.7/ 6.9/ 12.1/ 2.3/ 1.5 3.8/ 0.9 3.8/ 0.9 3.8/ 2.2 2.7/ 1.1	6.9/ 12.1/ 8.8/ 15.4/	6.8/ 12.2/	6.9/ 12.4/ 5.9/ 9.9/ 7.5/ 12.8/	4.0/ 0.7 2.5/ 1.7 4.0/ 1.7 4.6/ 0.8										
SMI1755		6.5/ 11.8/ 5.9/ 11.0/ 4.9/ 2.8 3.8/ 2.4 3.8/ 2.4 4.4/ 2.3 5.3/ 3.1	5.4/ 9.9/ 6.4/ 10.9/		6.0/ 10.6/ 6.3/ 11.5/ 6.7/ 11.9/	3.9/ 7.7/ 5.7/ 10.2/										
Ssp1378		5.5/ 9.2/ 6.6/ 11.9/ 3.2/ 0.9 3.2/ 0.9 4.2/ 1.8 4.4/ 1.3 0.6/ 0.0	6.4/ 11.4/ 8.6/ 15.0/	6.1/ 10.1/	1.5/ 2.9/ 7.9/ 13.2/ 6.6/ 10.7/	5.5/ 11.6/ 6.8/ 11.9/ 6.1/ 10.6/										
WIE1382		2.8/ 4.7/ 6.4/ 11.8/ 0.8/ 1.0 2.3/ 0.6 2.3/ 0.6 3.6/ 1.8 3.0/ 2.0	8.2/ 14.3/ 5.3/ 8.5/		4.2/ 2.2 5.3/ 1.4 3.6/ 1.0 4.2/ 0.7 5.3/ 2.7 3.2/ 1.3	5.2/ 10.8/ 6.8/ 11.8/ 5.8/ 10.5/	5.2/ 8.6/ 7.3/ 12.1/ 5.8/ 9.5/									
WIE1686		2.7/ 4.5/ 6.4/ 11.8/ 1.1/ 1.0 2.5/ 0.6 2.5/ 0.6 3.4/ 1.8 3.2/ 2.0	8.2/ 14.5/ 5.3/ 8.4/		3.0/ 1.3 3.6/ 2.2 3.8/ 1.5 3.2/ 1.2 2.7/ 1.5 4.4/ 2.6 2.7/ 1.3	5.4/ 11.2/ 6.5/ 11.4/ 5.8/ 10.5/	5.1/ 8.5/ 7.4/ 12.4/ 5.9/ 9.8/							0.5/ 0.9/		
WIE1687		3.0/ 5.1/ 6.5/ 11.9/ 1.1/ 0.9 2.5/ 0.7 2.5/ 0.7 3.4/ 1.9 3.2/ 1.9	8.1/ 14.3/ 5.3/ 8.4/		2.7/ 1.3 3.4/ 2.2 3.6/ 1.5 3.4/ 1.2 2.5/ 1.5 4.2/ 2.6 3.0/ 1.3 0.2/ 0.0	5.4/ 11.1/ 6.7/ 11.8/ 5.8/ 10.4/	5.2/ 8.9/ 7.6/ 12.8/ 6.1/ 10.1/							0.7/ 1.1/ 0.7/ 1.2/		
SEX1364		16.5/ 24.4/ 16.2/ 23.9/ 13.1/ 6.7 13.5/ 6.6 13.5/ 6.6 14.8/ 7.0 13.3/ 6.7	16.3/ 24.0/ 16.6/ 24.2/ 16.5/ 24.4/	16.6/ 24.6/ 16.6/ 24.6/ 16.6/ 24.6/ 16.3/ 24.0/ 12.3/ 18.4/ 16.4/ 24.3/ 16.3/ 24.5/ 16.2/ 24.3/	16.4/ 24.4/ 16.6/ 24.6/ 15.5/ 26.0/ 16.3/ 24.0/ 12.3/ 18.4/ 16.4/ 24.3/ 16.3/ 24.5/ 16.2/ 24.3/	13.3/ 6.6 13.9/ 6.6 13.9/ 6.6 13.9/ 6.7 13.5/ 6.7 12.4/ 7.0 13.7/ 6.5 12.4/ 6.6 12.4/ 6.6										

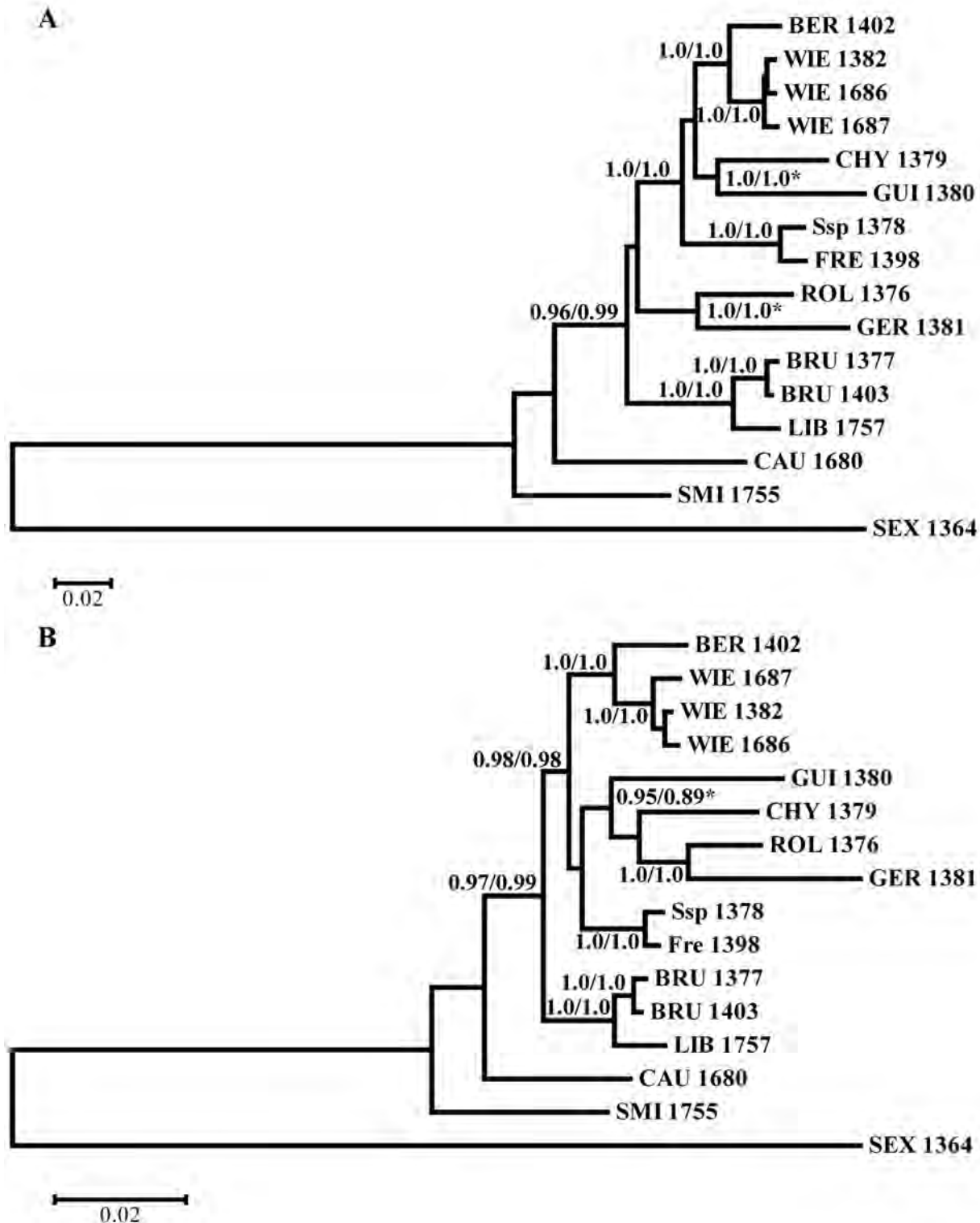

Fig. 3. Results of the Bayesian analyses. Shown is the consensus tree of the analysis with the complete dataset and NST=6 (**A**) and the consensus tree of the dataset with excluded alignment columns with missing data and NST=6 (**B**). Values left to nodes are the corresponding posterior probability values, except for values marked with * which are on the right side of the corresponding node (complete dataset, NST=2 / complete dataset, NST=6 in **A**; alignment columns with missing data excluded, NST=2 / alignment columns with missing data excluded, NST=6 in **B**). Values for nodes were only given, if at least one analysis has a posterior probability above 0.95.

All three maximum parsimony analyses result in nearly the same tree topology and differ only in branch length and bootstrap support values; here, only one of three shortest trees of the complete dataset is presented (Fig. 2). The Bayesian analyses for the complete and the reduced datasets show slightly different tree topologies, independent if the analyses were performed with NST=6 or 2. Shown are the results for the complete and the reduced dataset of the NST=6 analyses, on the nodes posterior probabilities for both analyses for each dataset are presented if the values are equal to or above 0.95 (Fig. 3 A+B).

Scriptaphyosemion schmitti and *S. cauveti* are supported as basal to all other species of the genus (Figs 2–3). As *S. schmitti* was placed in the study of Murphy et al. (1999) within a clade containing the other *Scriptaphyosemion* species studied, we checked for possible causes of this discrepancy. As the sequences studied here have no overlap with those of Murphy et al. (1999), we compared a cytochrome b fragment of our sample with the data deposited in GenBank. However, both samples differ in only one nucleotide (results not shown), and a Blast search with our analysed sequences (see Table 1) only returned the highest similarity with other *Scriptaphyosemion* sequences. To exclude that the basal position of *S. schmitti* is an artifact due to the missing sequence data, we also performed the analyses with the reduced dataset, which did not contain missing data, but gave the same results (Figs 2–3). However, further samples should be studied for a confirmation of the basal position, especially as this node is supported neither by bootstrap nor posterior probability values.

Our results indicate a closer relationship between *S. liberiense* and *S. brueningi*, *S. roloffii* and *S. geryi*, *S. fredrodi* and a probably undescribed species (see under Discussion), and *S. bertholdi* and *S. wieseae*, new species. A closer relationship between *S. chaytori* and *S. guignardi* occurs in all resulting trees (Figs 2–3), but is well supported only in the Bayesian analyses of the complete dataset. Both species were in addition grouped with *S. roloffii* and *S. geryi* in the analyses of the reduced dataset, but not in the maximum parsimony analyses and the Bayesian analyses of the complete dataset (Figs 2–3).

All analyses support a monophyletic group formed by all *Scriptaphyosemion* except of *S. schmitti* and *S. cauveti* (Figs 2–3). Another well supported subgroup is formed by *S. bertholdi*, *S. wieseae*, new species, *S. chaytori*, *S. guignardi*, *S. fredrodi*, and *S. sp.* (see under Discussion); only in the analyses of the reduced dataset *S. roloffii* and *S. geryi* were also included in this group (Fig. 2–3). To this subgroup, *S. brueningi* and *S. liberiense*, probably is the sister group, a hypothesis only significantly supported in the Bayesian analyses (Fig. 3).

The phylogenetic results show that *S. bertholdi* is the well supported sister species to *S. wieseae*, new species, and indicates no closer relationship to other mentioned

species. The genetic distance values (Table 2) show a similar divergence as between *S. liberiense* and *S. brueningi*.

Scriptaphyosemion wieseae, new species

(Fig. 4, Table 3)

Scriptaphyosemion sp. Lenghe Curoh: Busch (1995a), Vandersmissen (2003)

Holotype. ZFMK 47680, male, 36.1 mm SL, Sierra Leone, Lenghe Curoh, Sanghi or Sanigi River, field number SL 03/16 (9°28,04' N, 11°40,58' W), E. Busch and B. Wiese, 18. Nov. 2003.

Paratypes. ZFMK 47681–47692, 8 males, 4 females, 19.5–34.7 mm SL, paratopotypes, collected with the holotype.

MRAC B2-06-P-1–2, 1 male, 22.9 mm SL, 1 female, 21.5 mm SL, paratopotypes, collected with the holotype.

ZFMK 47693–47707, 7 males, 8 females, 18.8–41.3 mm SL, Sierra Leone, Fadugu, at the bridge over the Mabakah River, field number SL 03/15 (9°23,52' N, 11°45,76' W), E. Busch and B. Wiese, 18. Nov. 2003.

ZSM 41596 (2), 1 male, 28.4 mm SL, 1 female, 22.3 mm SL, collected with ZFMK 47693–47707.

Non-type DNA samples. RS1686, 1 male, DNA voucher, preserved in 96 % ethanol, collected with ZFMK 47693–47707, field number SL 03/15; RS1382, 2 males, 1 female, DNA voucher, preserved in 96 % ethanol, collected with the holotype; RS1687, 1 male, DNA voucher, preserved in 96 % ethanol, Sierra Leone, Kabala, collected in rice swamp, field number SL 03/17 (9°35' N, 11°33' W), E. Busch and B. Wiese, 18. Nov. 2003.

Diagnosis. *Scriptaphyosemion wieseae* is distinguished from its congeners by a unique combination of male and female coloration characters. Males have a blue body color, red dots on side forming irregular, interrupted red stripes, especially on caudal peduncle a more reticulated pattern, unpaired and pelvic fins centre blue with a narrow blue margin and a broad red submargin, on anal and dorsal fin a small number of basal red blotches, centre of caudal fin with some red blotches, pectoral transparent to orange with a blue margin; females with a dark brown midlateral stripe, interrupted on caudal peduncle, body on lower half of side and ventrally orange vs. a mainly red lateral body color in male *S. cauveti*; head and anterior body yellowish to brownish, unpaired fin margins white or yellow, and pectoral fin margin yellow to orange in male *S. schmitti*; males with more or less regular oblique red bars on side, at least on the caudal peduncle, fin margins, especially of caudal and pectoral, often yellow, and females with dark brown streaks or blotches, similar to the

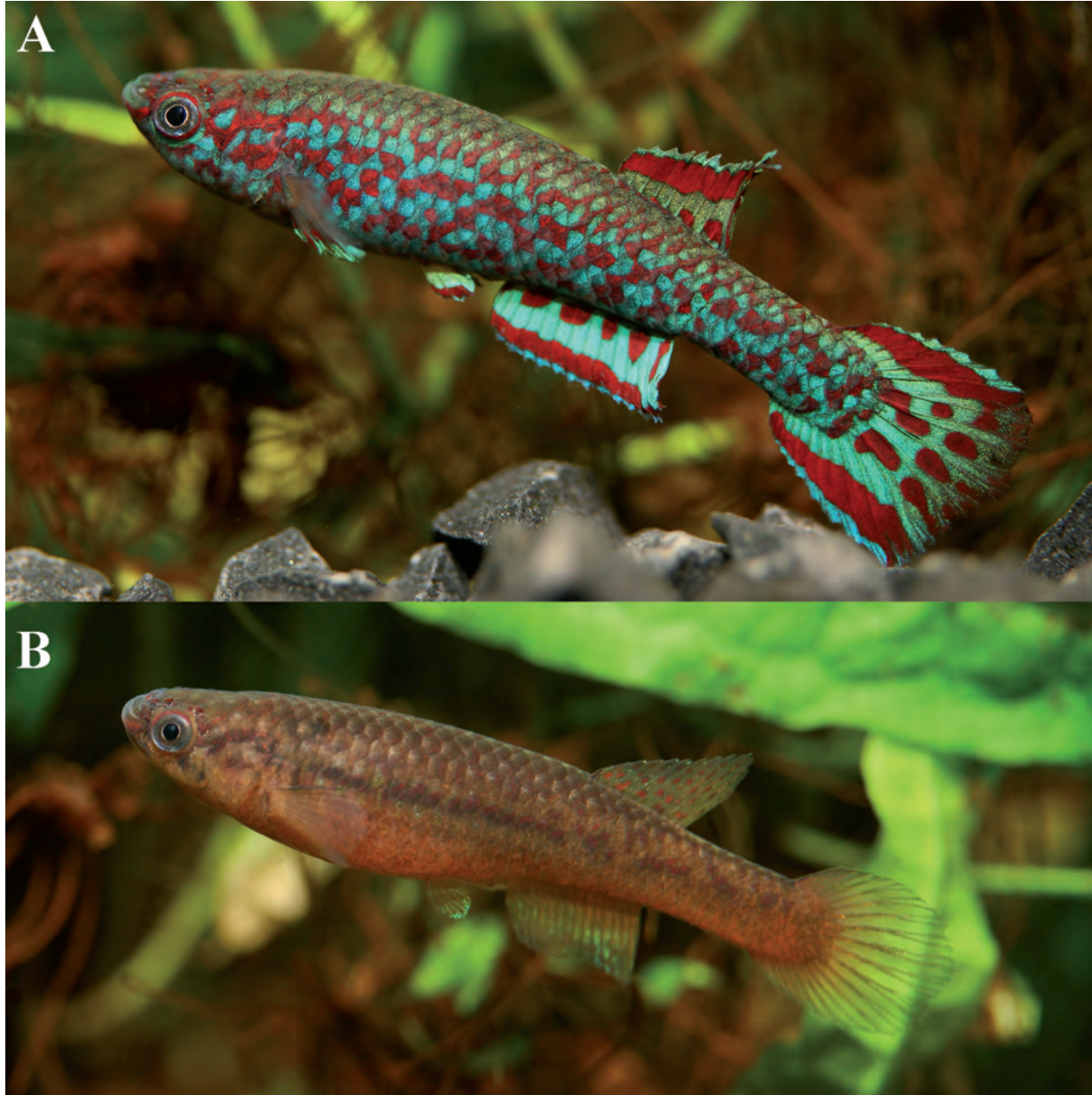

Fig. 4. **A)** Male of *Scriptaphyosemion wieseae*, collection locality SL 03/16, not preserved. **B)** Female of *Scriptaphyosemion wieseae*, collection locality, SL 03/16, not preserved.

red oblique bars of males on side, often with a dark blotch at the root of the caudal in *S. geryi* and *S. roloffii*; males with broad red blotches, often forming broad irregular vertical stripes, caudal fin margins yellow, often with a small white submargin followed by a broader red band, females with irregularly distributed dark brown dots or short oblique streaks or blotches dorsally on the caudal peduncle, a weak anterior dark lateral band, and a dark blotch on the posterior dorsal end of the caudal peduncle at the caudal fin base in *S. brueningi*; often yellow, sometimes whitish caudal fin margins in males, females with irreg-

ularly distributed dark brown or red dots on side in *S. chaytori*; males with dark red blotches on side, caudal fin margins whitish to light blue or yellow, pectoral fin margin white, females with dark brown blotches or oblique short streaks on dorsal half of caudal peduncle and a dark blotch on posterior end of caudal peduncle at dorsal base of caudal fin in *S. fredrodi*; males with light blue to blue-green body color, many irregularly distributed small red streaks or dots, submarginal stripes of unpaired fins dark red to nearly black, margins light blue or whitish, sometimes on dorsal and often on anal absent, females with red

Table 3. Morphometrics of *Scriptaphyosemion wieseae*, new species. Values in the table are based on 15 specimens, for which all measurements and counts were taken (7 of each male and female paratypes). All measurements in percentages of standard length (SL) except standard length in mm. TL = total length, HL = length of head, PD = predorsal fin distance, pPED = prepectoral fin distance, pPD = prepelvic fin distance, pAD = preanal fin distance, DB = greatest body depth, DC = caudal peduncle depth, CL = length of caudal peduncle, BD = base of dorsal fin, BA = base of anal fin, E = eye diameter, I = interorbital width, SD = standard deviation.

	Holotype	Paratypes ♂ mean	Paratypes ♀ mean	all Types mean	all Types range	all Types SD
SL	36.0	25.1	24.7	25.6	21.5–36.0	4.0
TL	119.7	124.4	122.5	123.2	119.7–127.0	2.2
HL	26.3	26.6	26.9	26.7	25.1–28.9	1.3
PD	66.0	65.1	64.9	65.0	61.2–67.8	2.0
pPED	27.7	27.4	27.9	27.6	25.9–29.8	1.1
pPD	45.3	47.2	46.6	46.8	44.7–49.4	1.3
pAD	57.3	57.8	57.5	57.7	54.9–59.8	1.5
DB	19.5	19.8	19.3	19.6	18.7–21.7	0.8
DC	12.3	11.9	11.4	11.7	10.9–12.3	0.5
CL	23.3	22.4	22.5	22.5	21.1–23.6	0.7
BD	17.6	16.3	15.7	16.1	14.4–17.6	1.0
BA	21.1	20.4	19.1	19.8	17.9–21.5	1.0
E	5.4	6.5	6.5	6.4	5.4–7.3	0.5
I	11.2	9.5	9.6	9.7	8.6–11.2	0.6

or dark brown dots on side, on some specimens nearly linear arranged, on others more irregular, in *S. guignardi*; mostly yellow or whitish caudal fin margins in males, irregular dark blotches on dorsal half of side in females, according to the first description (Boulenger 1908), in *S. liberiense*.

Scriptaphyosemion wieseae males (Fig. 4A) differ from its closest relative, *S. bertholdi* (Fig. 5A), by coarser and often denser red pigmentation on body and fins and broader dots or short streaks in the caudal fin, caudal fin truncate vs. small dots on body and fins, especially in the caudal fin, caudal rounded in *S. bertholdi* males. Females of *S. wieseae* (Fig. 4B) have a midlateral more or less complete dark stripe, often interrupted posterior to origin of anal fin on caudal peduncle, ventral half of sides below midlateral dark stripe often intense orange in wild caught specimens or orange-brown in aquarium kept specimens vs. irregularly distributed dark brown dots on scales on dorsal half of side, pale brownish-orange on anterior side in females of *S. bertholdi* (Fig. 5B).

Description. See Figure 4 for overall appearance and Table 3 for morphometric and meristic values of the type series. *Scriptaphyosemion wieseae* shows a strong sexual dimorphism with males more colorful, usually larger, and with slightly extended fin rays in unpaired fins. Body cylindrical, elongate, and laterally slightly compressed. Dorsal profile slightly convex, ventral profile anteriorly slightly convex, slightly concave to nearly straight on cau-

dal peduncle, greatest body depth approximately anterior to origin of pelvic fin.

Snout slightly pointed, mouth directed upwards, lower jaw longer than upper jaw, posterior end of rictus at the level of the dorsal third to centre of eye. Teeth curved and unicuspid, on dentary an outer row of larger teeth, inner rows more or less regular with smaller teeth. Premaxilla with an outer row of larger teeth and a small number of short teeth irregularly on the inner part. Closed frontal neuromast system within one groove, preopercular neuromast system with 5 pores.

Scales cycloid, body and head completely scaled, except for ventral surface of head. Frontal squamation of G-type; scales on lateral line 27–30 + 2–3 scales on caudal fin base. Transverse rows of scales above pelvic fin 9; circumpeduncular scale row 12–14.

Tips of dorsal, anal, and, in some males, also caudal fin slightly pointed, but no filamentous extensions, caudal fin truncate. Fins in females are generally smaller and more rounded. Dorsal and anal fin origin posterior to mid-body. First dorsal fin ray posterior to origin of anal fin, situated above anal fin ray 4–6. Dorsal fin with 12–13 rays, anal with 16–17 rays, caudal fin with 25–28 fin rays. Pectoral fin rounded, fin origin on ventral half of side, just posterior to operculum, directed posteriorly, not reaching pelvic fin origin. Pelvic fin small, origin ventrally, directed posteriorly, not or just reaching anal fin origin. Total number of vertebrae 29–30, of which 13–14 have pleural ribs and 15–16 have haemal spines.



Fig. 5. **A)** Male of *Scriptaphyosemion bertholdi*, SL 93/51, Sierra Leone, Victoria, not preserved. **B)** Female of *Scriptaphyosemion bertholdi*, SL 93/51, Sierra Leone, Victoria, not preserved.

Live coloration. Males. (Fig. 4A) Lateral head blue with a slightly irregular red pattern typical for the endemic West African genera *Archiaphyosemion*, *Callopanchax*, *Nimbanpanchax*, and *Scriptaphyosemion* and the related *Epiplatys* (Van der Zee 2002). Lips dark grey, red line around mouth along upper and lower lip, small dark grey dot at chin, iris of eye grey, dorso-anterior with blueish or blue-greenish

hue, a light, reflecting ring around pupil. Dorsal from head to dorsal fin brownish, scales with some blue in centre and irregular red margins, forming an interrupted reticulated pattern. Flanks, unpaired fins and pelvic fins blue, dorsal and caudal fin centre often with a yellow hue, giving a more greenish impression of fin color. Red pigmentation on side in three to four very irregular stripes, consisting

of red blotches, especially on caudal peduncle looking more like an interrupted reticulation. Unpaired and pelvic fins with a narrow blue margin, sometimes slightly lighter than color of fin centre and body; the blue margin is followed by a broad red submargin. On base of dorsal, anal, pelvic, and centre of caudal fin a small number of red blotches, pectoral fin transparent with a blue margin and a, more or less complete, red submargin.

Females. (Fig. 4B) Body brownish, dorsally darker, on ventral half of side and belly orange. Pigmentation on head similar to males, but mostly darker brown instead of red. Midlateral dark brown stripe, interrupted and slightly irregular on caudal peduncle, scales in this dark stripe sometimes with small red scale margins; centre of unpaired and pelvic fins brown-orange, with a very narrow blueish margin, and a faint, narrow red submarginal, except on caudal fin. Above submarginal on anal and pelvic fins a small area with blueish or greenish hue, centre of dorsal fin with small red dots, basally larger than marginally. Pectoral fin transparent.

Color in ethanol. Males. Body brownish, darker on back and lighter on belly, red pigmentation pattern of live specimens is now carmine or dark brown, on ventral side of head a small grey blotch on chin. Fin color light brown, unpaired fins with a whitish margin and a carmine or dark brown sub-margin, some carmine or brown dots, pelvic fins with a dark brown margin.

Females. Similar to males body brown with a darker dorsal and lighter ventral part, on side the same dark brown pigmentation as in live specimens, on ventral side of head a grey blotch as in males. Fins light brown, on dorsal several small brown dots.

Distribution and habitat. *Scriptaphyosemion wieseae* is currently known from three localities in the upland of northern Sierra Leone between the Sula and Wara Wara mountains (Fig. 1); all of these are located within the Seli or Rokel River basin. At the collection localities Fadugu (SL 03/15) and Lenghe Curoh (SL 03/16), *S. wieseae* is present in small rivers, at the former place together with *Epiplatys* cf. *njalaensis*, *Archiaphyosemion guineense*, undetermined characids, gobies, and cyprinids, probably *Barbus leonensis*, *B. stigmatopygus* and a small undetermined *Barbus* specimen; at the latter place it was collected together with *A. guineense*. At Kabala (SL 03/17), only a small number of mostly juvenile specimens were collected in large rice swamps. The second author visited this area two times, in 1993 and 2003, and noticed an intensified agricultural land usage.

Collections of the second author during four collection trips between 1989 and 2003 suggest that there is no overlap of the distribution areas of *S. bertholdi* and *S. wieseae* (Fig. 1). *Scriptaphyosemion bertholdi* inhabits southeastern Sierra Leone and is found in river basins which enter

the Atlantic ocean through the southern costal area (Huber 2007; Wildekamp 1993; Wildekamp & Van der Zee 2003), whereas *S. wieseae* inhabits the upper tributaries of the Seli or Rokel River, which enter the Atlantic ocean more to the north (Fig. 1). The geographically closest *Scriptaphyosemion* species with regard to the known collection localities of *S. wieseae* is *S. chaytori* (Fig. 1), to the north in Guinea it is *S. guignardi* (Busch 1995a; Wildekamp & Van der Zee 2003; own unpublished collection data)

Etymology. The new species is named after Barbara Wiese, who accompanied the second author on most of his research trips in West Africa and was the first who recognized it as a new *Scriptaphyosemion* species.

DISCUSSION

Scriptaphyosemion wieseae is distinguished from the closely related *S. bertholdi* (Figs 2–3) by several diagnostic characters, and is probably separated by strong genetic incompatibilities (Vandersmissen 2003). As proposed by Roloff (1971a), female color characters can be useful for distinguishing between some *Scriptaphyosemion* species, here by the diagnostic lateral color pattern differences between *S. wieseae* (Fig. 4B) and *S. bertholdi* (Fig. 5B). However, female pigmentation pattern can be obscured by several factors, as e.g. stress, and vary in intensity (Roloff 1971a; own observations).

The combination of high variability in male coloration between isolated populations of one species and the often only small diagnostic color pattern differences between species can make species identification in *Scriptaphyosemion* difficult (Roloff 1971a; Scheel 1990).

The recent introduction of molecular methods in taxonomic and phylogenetic studies of nothobranchiid killifishes added an additional and independent set of characters and helped to resolve complicated cases of species level taxonomy (e.g. Legros & Zentz 2007b; Legros et al. 2005; Sonnenberg 2007, 2008). This approach can also be applied to resolve the taxonomy of *Scriptaphyosemion* by clarifying the relationships between species and pinpointing diagnostic characters in terms of morphology and color pattern.

Our present results are largely congruent with those of Murphy et al. (1999), if only the well supported nodes are considered. Differences e.g. in the placement of *S. roloffi* are based on different opinions on the species level taxonomy. Incongruences in the placement of some species and low support of several nodes might be based on insufficient information content in the dataset.

The perceived variability of male coloration in the absence of other diagnostic characters and different species concepts led to varied opinions concerning species valid-

ity and number between authors (e.g. Costa 2008; Huber 2007; Lazara 2001; Scheel 1968, 1990; Wildekamp 1993). Even decades after Roloff (1971a) and Scheel's (1990) comments on the taxonomic difficulties, the species level taxonomy of *Scriptaphyosemion* is still far from being resolved. Here we provide an overview of species names in *Scriptaphyosemion* and their synonyms, with short comments on species whose taxonomy needs a revision. We mainly follow the species level taxonomy as proposed by Costa (2008); the species concept employed is that of Moritz et al. (2000).

The following species, *S. bertholdi*, *S. brueningi*, *S. chaytori*, *S. fredrodi*, and *S. schmitti* have comparatively smaller distribution areas, and usually show less variability in the diagnostic characters than the species listed below. They are, with the exception of *S. fredrodi*, concordantly considered as valid species by most authors (Costa 2008; Huber 2007; Lazara 2001; Wildekamp & Van der Zee 2003). In addition, the studied samples of these species show considerable genetic distance with regard to their closest relatives within the molecular phylogenies (Figs 2–3, Murphy et al. 1999), supporting their status as separate species.

Scriptaphyosemion geryi is distributed from northern Sierra Leone to the Senegal (Wildekamp 1993; Wildekamp & Van der Zee 2003). Within this large area, differences in coloration pattern between populations are known (e.g. Cauvet 2008; Etzel & Berkenkamp 1979; Wildekamp 1993), indicating that probably more than one species is currently included under this name.

Scriptaphyosemion guignardi was the first of three formally described species of a species complex (Romand 1981, 1982; Seegers 1982). According to the DNA study of Murphy et al. (1999), these three species form a monophyletic group. Costa (2008) listed them as valid species, but Etzel & Berkenkamp (1989a, b) and Etzel & Vandersmissen (1984), based on crossing experiments, regard *S. nigrifluvi* and *S. banforense* as junior synonyms of *S. guignardi*. A short comparison of the published cytochrome b sequences of Murphy et al. (1999) indicate considerable genetic divergence between the three studied specimens (4.9–10.8 %) which is in the range of intraspecific divergence values in killifishes (Murphy et al. 1999; Sonnenberg 2007, 2008; Sonnenberg & Blum 2005; Van der Zee & Sonnenberg 2011; own unpublished data). In addition, these species share some coloration characters, which indicates their close phylogenetic relationship. Still they are diagnosable by male coloration characters. Studies employing crossing experiments (e.g. Etzel & Berkenkamp 1980a, b, c, 1989a, b; Etzel & Vandersmissen 1984; Romand 1986; Scheel 1968, 1990) show, that between many populations different levels of genetic incompatibility exist. However, the conclusion that successful crossings up to the third generation indicate that they are conspecific is viewed with strong hesitation. The difficulties of the

biospecies concept of Mayr (1963) is discussed in literature (e.g. Otte & Endler 1989), and recent examples of hybrid species and mitochondrial introgressions between species prove the possibility of fertile hybrids between distinct species (e.g. Nolte et al. 2005; Schliewen & Klee 2004; Schwarzer et al. 2011; Sonnenberg 2007). At the moment we follow Costa (2008) in regarding them as three separate species.

The description of *Scriptaphyosemion liberiense* is based on preserved females (Boulenger 1908). It has a large distribution in coastal Liberia (Wildekamp & Van der Zee 2003). *Aphyosemion calabaricus* Ahl, 1936, described on specimens from an ornamental fish import without secure collection locality, and *Epiplatys melantereon* Fowler, 1950 were considered as junior synonyms to *S. liberiense* (Costa 2008; Eschmeyer 2011; Huber 2007). However, *S. liberiense* in its current usage is rather variable in male phenotype between different populations (Etzel 1992, 1993; Milkuhn 2007, 2008; Wildekamp 1993). Roloff (1971b) proposed that *S. calabaricum* females differ in coloration pattern from *S. liberiense* as described by Boulenger (1908) and might represent a different species. A careful study of *S. liberiense* over its distribution range will be necessary to search for potentially separating stable diagnostic characters between groups of populations and to decide about the status of *S. calabaricum*. At the moment we tentatively consider this species as a synonym of *S. liberiense*.

Scriptaphyosemion roloffii was accidentally described by Roloff (1936), the intended description by Ahl (1937) followed a year later. Both authors gave a detailed color pattern description of the new species, drawings or black and white pictures, the latter ones from E. Roloff or W. Harvey, were published by different authors (e.g. Henzelmann 1937; Mayer 1937; Ott 1997). By later authors (e.g. Etzel 1978c; Scheel 1968, 1990; Wildekamp 1993) the identity of *S. roloffii* was confused due to the inclusion of different populations, which do not show the diagnostic characters of the specimens described by Roloff (1936) and Ahl (1937) and probably represent different species. Etzel & Berkenkamp (1980a, b, c) presented the results of crossing experiments between different populations, which were assumed to be *S. roloffii*, but most probably included at least one currently undescribed species, judged from the published drawings. In 1979, *S. etzeli* was described by Berkenkamp, based on specimens which show the same coloration characters as given in the description of *S. roloffii* (Ahl 1937; Henzelmann 1937; Mayer 1937; Roloff 1936). The synonymy of *S. etzeli* with *S. roloffii* in the sense of Roloff (1936) and Ahl (1937) was discussed by Busch (1995b, 1996) and Ott (1997). We are of the opinion that *S. etzeli* is a junior synonym of *S. roloffii*, based on the diagnostic coloration characters of males and females, and that *S. roloffii* in the current usage (Berkenkamp 1979; Etzel & Berkenkamp 1980a, b, c; Et-

zel 1978a, c; Etzel et al. 2004; Huber 2007; Wildekamp 1993) probably contains at least one undescribed species.

The incongruence of the placement of *S. roloffi* between our study (Figs 2–3) and Murphy et al. (1999) is caused by different taxonomic concepts. Their *S. etzeli* is in our view *S. roloffi* and the *S. roloffi* sample in their study most probably is an undescribed species. The voucher of *Scriptaphyosemion* sp. in our DNA analyses (Figs 2–3) belongs to the group of populations currently considered by other authors as conspecific with *S. roloffi*. However, it does not show the diagnostic coloration characters of this species and belongs to a different genetic lineage, closer to *S. fredrodi*, and might probably be an undescribed species related to that labeled as *S. roloffi* in Murphy et al. (1999). *Scriptaphyosemion hastingsi* (Wright, 1972), also was an accidental description, but should be restudied by new collections with regard to the species complex currently included in *S. roloffi*, to which it is currently considered as a synonym (e.g. Eschmeier 2011; Huber 2007; Wildekamp 1993). We tentatively consider it as a synonym, but it might turn out to be a valid name for a species currently included in *S. roloffi*.

For the two species names, *Roloffia caldal* Cahalan, 1973 and *Aphyosemion muelleri* Scheel, 1968, we follow other authors (Eschmeyer 2011; Huber 2007; Wildekamp 1993), who consider them as invalid or not available, as they were not mentioned by Costa (2008).

COMPARATIVE MATERIAL

Scriptaphyosemion bertholdi (Roloff, 1965): ZFMK 47708–47714, Sierra Leone, Victoria, collection locality SL 93/51.

Scriptaphyosemion brueningi (Roloff, 1971b): ZFMK 47715–47725, Sierra Leone, Perie, collection locality SL 89 Perie; ZFMK 47726–47735, Sierra Leone, Tawai, collection locality SL 03/2.

Scriptaphyosemion calabaricum (Ahl, 1936): ZMB 21039, Lectotype, Nigeria (probably from Liberia); ZMB 31494, Paralectotype, collected with the Lectotype.

Scriptaphyosemion cauveti (Romand & Ozouf-Costaz, 1995): ZFMK 47736–47739, Guinea, Kamara Bounyi, collection locality GM 97/5.

Scriptaphyosemion chaytori (Roloff, 1971a): ZFMK 47740–47755, Sierra Leone, Kamabai, collection locality SL 93/34; ZFMK 47756–47760, Sierra Leone, Nom-Mussiray, collection locality SL 93/38.

Scriptaphyosemion fredrodi (Vandersmissen, Etzel & Berkenkamp, 1980): ZFMK 47761–47775, Sierra Leone, Matanga, collection locality SL 89 Matanga.

Scriptaphyosemion geryi (Lambert, 1958): ZFMK 47776–47780, Sierra Leone, Rotain, collection locality SL 89 Rotain.

Scriptaphyosemion guignardi (Romand, 1981): ZFMK 47781–47782, Guinea, Gubi, collection locality GM 97/13.

Scriptaphyosemion liberiense (Boulenger, 1908): BMNH 1903.6.3.17–18, syntypes, Liberia, Monrovia; ZFMK 47783–47785, Liberia, Paynesville, collection locality L97; ZFMK 12163, Liberia, surrounding of Monrovia, commercial import; ZFMK 12659–662, Liberia, Totota.

Scriptaphyosemion melantereon (Fowler, 1950): ANSP 72125, Holotype, Liberia, Robertsport; ANSP 72126–27, Paratypes, collected with holotype.

Scriptaphyosemion roloffi (Roloff, 1936): ZMB 21071, Lectotype, Sierra Leone, tribuary of Port Loko Creek, ca. 40 km east-northeast of Freetown, ZMB 31472, Paralectotypes, collected with Lectotype; ZFMK 47786–47798, Sierra Leone, Malai, collection locality SL 03/11; ZFMK 47799–47813, Sierra Leone, Lungi Lol, collection locality SL 99/10; ZFMK 12678–80 (as *S. etzeli*), Sierra Leone, Port Loko district, Kirma.

Scriptaphyosemion schmitti (Romand, 1979): ZFMK 47814–47815, Liberia, Juarzon, aquarium bred specimens.

Scriptaphyosemion sp. aff. *roloffi*: ZFMK 47816–47819, Sierra Leone, Devil Hole, collection locality SL 03/18; ZFMK 47820–47825, Sierra Leone, Kundubu, collection locality SL 93/6; ZFMK 12656–58, Sierra Leone, Magbenta; ZFMK 14808–11, Sierra Leone, 15 km north Bo.

Acknowledgements. EB thanks Mohamed Basiru and family (Brama Village, Sierra Leone) and the people of Brama Village for hospitality, organization and help during field work at four research trips in Sierra Leone, Wilhelm Kugelmann (Dinkelscherben, Germany) for his support in keeping and breeding many species collected on several journeys, and Barbara Wiese (Remscheid, Germany) for her support on many research trips in West Africa since years. RS thanks Peter Bartsch and Christa Lamour (MfN, Berlin, Germany), and Oliver Crimmen and James Maclaine (NHM, London, Great Britain) for kind access to the collection under their care, Klaus Busse and Fabian Herder (ZFMK, Bonn, Germany) for access to the collection and the X-ray device, Kyle Luckenbill, John Lundberg, and Mark Sabaj Perez (ANSP, Philadelphia, USA) for data, X-rays, and photos of type specimens under their care, Diethard Tautz (MPI, Plön, Germany) for support with lab space and access to the micro Computer Tomograph, Heinz Otto Berkenkamp (Wilhelmshaven, Germany), Gerhard Schreiber (Lüdenscheid, Germany), Thomas Litz (Attenweiler, Germany) for support with Literature. We thank Günther Fleck (Saint-Gaudens, France) for the translation of the Abstract, Anja C. Schunke (MPI, Plön, Germany) for comments and corrections on an earlier version of the manuscript, and Fabian Herder and two anonymous reviewers for valuable comments.

REFERENCES

- Agnès J-F, Brummet R, Caminade P, Catalan J, Kornobis E (2009) Genetic characterization of the *Aphyosemion calliurum* species group and description of a new species from this assemblage: *A. campomaanse* (Cyprinodontiformes: Aplocheiloidei: Nothobranchiidae) from Southern Cameroon. *Zootaxa* 2045: 43–59
- Ahl E (1936) Beschreibung eines neuen Zahnkarpfens aus Westafrika. *Sitzungsberichte der Gesellschaft Naturforschender Freunde zu Berlin* 1935 (3): 402–403
- Ahl E (1937) Über eine kleine Fischesammlung aus Sierra Leone. *Mitteilungen aus dem Zoologischen Museum in Berlin* 22: 239–241
- Amiet JL (1987) Le Genre *Aphyosemion* Myers (Pisces, Teleostei, Cyprinodontiformes). *Faune du Cameroun*, Volume 2. Sciences Nat, Compiègne, France
- Berkenkamp HO (1979) Description provisoire de *Roloffia etzeli* sp. nov. un nouveau cyprinodontidae de Sierra Leone. *Association Killiphile Francophone de Belgique, Killi-Contact* 7: 1–11

- Boulenger GA (1908) Descriptions of two new cyprinodontid fishes from West Africa. *The Annals and Magazine of Natural History* (8) 2 (7): 29–30
- Busch E (1995a) „SL 93“ - Eine erneute Sammelreise nach Sierra Leone im Überblick. *Deutsche Killifisch Gemeinschaft Journal* 27: 69–74
- Busch E (1995b) Systematikken hos *Roloffia* - Sierra Leones Fauna, 1. Del. *Roloffia etzeli* - den ægte *Roloffia roloffi*. *SKS Killibladet* 1995 (3): 22–28
- Busch E (1996) On the Systematics of the *Roloffia*-Fauna of Sierra Leone. Part 1. *British Killifish Association, Killi News* 365: 16–20
- Cahalan TL (1973) *Roloffia* „Caldal“. *American Killifish Association, Killie Notes* 6: 15–18
- Cauvet C (2008) Aufsammlungen von Killifischen in der Republik Guinea – 13 Jahre später. *Deutsche Killifisch Gemeinschaft Journal* 40: 14–24
- Costa WJEM (2008) Catalog of aplocheiloid killifishes of the world. UFRJ, Departamento de Zoologia, Rio de Janeiro
- Eschmeyer WN (ed.) *Catalog of Fishes electronic version* (30 November 2011). <http://research.calacademy.org/ichthyology/catalog/fishcatmain.asp> (last visited 18 December 2011)
- Etzel V (1977) Killifisch-Studien in Sierra Leone. 1. Allgemeines und Killifische der Halbinsel Sierra Leone. *Deutsche Killifisch Gemeinschaft Journal* 9: 189–199
- Etzel V (1978a) Killifisch-Studien in Sierra Leone. 2. Killifische der Distrikte Port Loko and Kambia. *Deutsche Killifisch Gemeinschaft Journal* 10: 9–20
- Etzel V (1978b) Killifisch-Studien in Sierra Leone. 3. Killifische des Distriktes Moyamba. *Deutsche Killifisch Gemeinschaft Journal* 10: 37–46
- Etzel V (1978c) *Roloffia roloffi*-Populationen der West-Region von Sierra Leone. *Deutsche Killifisch Gemeinschaft Journal* 10: 143–151
- Etzel V (1984) Killifisch-Studien in Sierra Leone. 4. Die Distrikte Pujehun und Kenema. *Deutsche Killifisch Gemeinschaft Journal* 16: 33–36
- Etzel V (1992) Killifischstudien in Liberia. Biotope und Fische in West-Liberia. *Deutsche Killifisch Gemeinschaft Journal* 24: 113–120
- Etzel V (1993) Killifischstudien in Liberia. Biotope und Fische Zentral-Liberias. *Deutsche Killifisch Gemeinschaft Journal* 25: 33–40
- Etzel V, Berkenkamp HO (1979) *Roloffia geryi* (Lambert, 1958). *Deutsche Killifisch Gemeinschaft Journal* 11: 81–88
- Etzel V, Berkenkamp HO (1980a) Kreuzungsexperimente mit *Roloffia roloffi*-Populationen der Westregion Sierra Leones I. *Deutsche Killifisch Gemeinschaft Journal* 12: 59–63
- Etzel V, Berkenkamp HO (1980b) Kreuzungsexperimente zur Identifizierung eines *Roloffia*-Wildfangs und von *Roloffia* „caldal“. *Deutsche Killifisch Gemeinschaft Journal* 12: 65–72
- Etzel V, Berkenkamp HO (1980c) Kreuzungsexperimente mit *Roloffia roloffi*-Populationen der Westregion Sierra Leones II. *Deutsche Killifisch Gemeinschaft Journal* 12: 137–144
- Etzel V, Berkenkamp HO (1989a) Kreuzungsexperimente zur Klärung der systematischen Einordnung von *Roloffia banforensis* SEEGERS, 1982 und *Roloffia guignardi* ROMAND, 1981. *Deutsche Killifisch Gemeinschaft Journal* 21: 21–30
- Etzel V, Berkenkamp HO (1989b) Kreuzungsexperimente zur Klärung der systematischen Einordnung von *Roloffia banforensis* SEEGERS, 1982 und *Roloffia guignardi* ROMAND, 1981 (Teil II). *Deutsche Killifisch Gemeinschaft Journal* 21: 33–40
- Etzel V, Berkenkamp HO, Effkemann S, Schlegel M (2004) Bemerkungen zur Identität von *Roloffia roloffi* – zum 100. Geburtstag von Erhard Roloff. *Cuxhavener Aquaristische Mitteilungen* 1: 7–42
- Etzel V, Vandersmissen J-P (1984) *Roloffia nigrifluvi* = *Roloffia banforensis*. *Der Hüpfertling* 2: 59–62
- Fowler HW (1950) Some fishes from Liberia, West Africa, with descriptions of two new species. *Notulae Naturae (Philadelphia)* 225: 1–8
- Gill T (1862) On the West African genus *Hemichromis* and description of new species in the Museum of the Academy and Smithsonian Institution. *Proceedings of the Academy of Natural Sciences of Philadelphia* 14: 134–139
- Hall TA (1999) BioEdit: a user-friendly biological sequence alignment editor and analysis program for Windows 95/98/NT. *Nucleic Acids Symposium Series* 41: 95–98
- Henzelmann E (1937) Etwas über Haltung und Zucht von *Aphyosemion roloffi*. *Wochenschrift für Aquarien- und Terraristik* 34: 65
- Hoedeman J (1958) The frontal scalation pattern in some groups of toothcarps (Pisces: Cyprinodontiformes). *Bulletin of Aquatic Biology* 1: 23–28
- Huber J-H (2007) Killi-Data 2007. Updated checklist of taxonomic names, collecting localities & bibliographic references of oviparous Cyprinodontiformes fishes (Atherinomorpha, Pisces). Killi-Data Editions, Paris (german edition)
- Huelsenbeck JP, Ronquist F (2001) MRBAYES: Bayesian inference of phylogeny. *Bioinformatics* 17: 754–755
- Lambert JG (1958) Poissons Siluriformes et Cyprinodontiformes récoltes en Guinée française, avec la description d'une nouvelle espèce de *Microsynodontis*. *Revue de Zoologie et de Botanique Africaines* 57: 39–56
- Lazara KJ (2001) The Killifishes. An annotated checklist, synonymy, and bibliography of recent oviparous cyprinodontiform fishes. *The Killifish Master Index* 4. The American Killifish Association
- Legros O, Zentz F (2007a) *Aphyosemion lividum* n. sp. (Cyprinodontiformes: Nothobranchiidae), un nouvelle espèce originaire de la région d'Edéa au Cameroun. *Association Killiphile Francophone de Belgique, Killi-Contact* 35: 1–34
- Legros O, Zentz F (2007b) *Aphyosemion malumbresi* n. sp., un nouveau *Chromaphyosemion* (Teleostei: Aplocheilidae) originaire de Guinée Equatoriale continentale. *Association Killiphile Francophone de Belgique, Killi-Contact* 35: 1–28
- Legros O, Zentz F, Agnès JF (2005) Description de deux nouveaux *Chromaphyosemion* (Teleostei: Aplocheilidae) du sud de la Plaine littorale camerounaise. *Association Killiphile Francophone de Belgique, Killi-Contact* 33: 3–30
- Mayer F (1937) Die beiden *Aphyosemion*-Arten *calabaricus* und *roloffi* E. Ahl. *Wochenschrift für Aquarien- und Terraristik* 34: 313
- Mayr E (1963) *Animal species and Evolution*. Harvard University Press, Cambridge, Massachusetts
- Milkuhn T (2007) *Scriptaphyosemion liberiense* – ein westafrikanischer Prachtkarpfing mit vielen Gesichtern. *Deutsche Killifisch Gemeinschaft Journal* 39: 58–64
- Milkuhn T (2008) *Scriptaphyosemion liberiense* – ein westafrikanischer killi med mange ansigter. *SKS Killibladet* 36 (3–4): 17–23
- Moritz C, Patton JL, Schneider CJ, Smith TB (2000) Diversification of rainforest faunas: an integrated molecular approach. *Annual Reviews in Ecology and Systematics* 31: 533–563
- Murphy WJ, Nguyen, TN, Taylor EB, Collier, GE (1999) Mitochondrial DNA Phylogeny of West African Aplocheiloid Killifishes

- liffishes (Cyprinodontiformes, Aplocheilidae). *Molecular Phylogenetics and Evolution* 11: 343–350
- Myers GS (1933) The Genera of Indo-Malayan and African Cyprinodont Fishes related to *Panchax* and *Nothobranchius*. *Copeia* 1933 (4): 180–185
- Nolte AW, Freyhof J, Stemshorn KC, Tautz D (2005) An invasive lineage of sculpins, *Cottus* sp. (Pisces, Teleostei) in the Rhine with new habitat adaptations has originated from hybridization between old phylogeographic groups. *Proceedings of the Royal Society Series B* 272: 2379–2387
- Ott D (1997) Zur Validität der Gattung *Roloffia* sowie zur *Roloffia-roloffi/etzeli*-Frage. *Deutsche Killifisch Gemeinschaft Journal* 29: 110–119
- Otte D, Endler JA (1989) *Speciation and its consequences*. Sinauer Associates, Inc., Sunderland, Massachusetts
- Paugy D, Lévêque C, Teugels GG, Bigorne R, Romand R (1990) Freshwater fishes of Sierra Leone and Liberia. Annotated checklist and distribution. *Revue Hydrobiologie tropicale* 23: 329–350
- Radda AC (1977) Vorläufige Beschreibung von vier neuen Subgenera der Gattung *Aphyosemion* Myers. *Aquaria* 24: 209–216
- Radda AC, Pürzl E (1987) *Colour Atlas of Cyprinodonts of the Rain Forests of Tropical Africa*. O. Hofmann-Verlag, Wien
- Roloff E (1936) Die Reise eines Aquarianers nach Westafrika (Schluß). *Wochenschrift für Aquarien- und Terrarienkunde* 33 (21): 324–326
- Roloff E (1965) *Aphyosemion bertholdi* spec. nov., eine neue *Aphyosemion*-Art aus Sierra Leone. *Die Aquarien und Terrarien Zeitschrift (DATZ)* 18: 362–364
- Roloff E (1971a) *Roloffia chaytori* spec. nov. Beschreibung einer neuen *Roloffia*-Art aus Sierra Leone. *Die Aquarien und Terrarien Zeitschrift (DATZ)* 24: 182–184
- Roloff E (1971b) *Roloffia brueningi* spec. nov. Beschreibung einer neuen *Roloffia* Art aus Sierra Leone. *Die Aquarien und Terrarien Zeitschrift (DATZ)* 24: 285–287
- Romand R (1979) Vorläufige Beschreibung von *Roloffia schmitti* spec. nov., einem neuen Killifisch aus Liberia. *Die Aquarien und Terrarien Zeitschrift (DATZ)* 32: 299–300
- Romand R (1981) Description d'un nouveau *Roloffia* de Guinée: *Roloffia guignardi* n. sp. (Pisces, Cyprinodontidae). *Revue française d'Aquariologie* 8: 1–7
- Romand R (1982) *Aphyosemion nigrifluvi* n. sp. une nouvelle espèce de Cyprinodontidae de Guinée (Pisces, Osteichthyes). *Revue française d'Aquariologie* 9: 77–82
- Romand R (1986) A study of *Aphyosemion schmitti* (Romand, 1979) and a survey of the *Aphyosemion* of Liberia (Pisces, Cyprinodontidae). *Zoological Journal of the Linnean Society* 87: 215–234
- Romand R, Ozouf-Costaz C (1995) *Aphyosemion cauveti*, a new species of killifish (Cyprinodontidae) from Guinea, West Africa. *Cybiurn* 19: 391–400
- Scheel JJ (1968) *Rivulins of the old world*. Tropical Fish Hobbyist Publication, Neptune City, New Jersey
- Scheel JJ (1990) *Atlas of the Killifishes of the old world*. Tropical Fish Hobbyist Publication, Neptune City, New Jersey
- Schliwien UK, Klee B (2004) Reticulate sympatric speciation in Cameroonian crater lake cichlids. *Frontiers in Zoology* 1, 5: 12 pp.
- Schwarzer J, Misof B, Schliwien UK (2011) Speciation within genomic networks: a case study based on *Steatocranus* cichlids of the lower Congo rapids. *Journal of Evolutionary Biology* 25: 138–148
- Seegers L (1982) *Roloffia banforensis* spec. nov. aus Obervolta. *Die Aquarien und Terrarien Zeitschrift (DATZ)* 35: 448–454
- Bonn zoological Bulletin 61 (1): 13–28
- Seegers L (1997) *Killifishes of the world*. Old World Killies I. Aqualog, A.C.S. GmbH, Mörfelden-Walldorf, Germany, 250 pp.
- Sonnenberg R (2007) Description of three new species of *Chromaphyosemion* Radda, 1971 (Cyprinodontiformes: Nothobranchiidae) from the coastal plains of Cameroon with a preliminary review of the *Chromaphyosemion splendopleure* complex. *Zootaxa* 1591: 1–38
- Sonnenberg R (2008) Two new species of *Chromaphyosemion* (Cyprinodontiformes: Nothobranchiidae) from the coastal plain of Equatorial Guinea. *Ichthyological Exploration of Freshwaters* 18: 359–373
- Sonnenberg R, Blum T (2005) *Aphyosemion (Mesoaphyosemion) etsamense* (Cyprinodontiformes: Aplocheiloidei: Nothobranchiidae), a new species from the Monts de Cristal, North-western Gabon. *Bonner zoologische Beiträge* 53: 211–220
- Sonnenberg R; Blum T, Misof B (2006) Description of a new *Episemion* species (Cyprinodontiformes: Nothobranchiidae) from northern Gabon and southeastern Equatorial Guinea. *Zootaxa* 1361: 1–20
- Sonnenberg R, Busch E (2009) Description of a new genus and two new species of killifish (Cyprinodontiformes: Nothobranchiidae) from West Africa, with a discussion of the taxonomic status of *Aphyosemion maeseni* Poll, 1941. *Zootaxa* 2294: 1–22
- Sonnenberg R, Busch E (2010) Description of *Callopanchax sidibei* (Nothobranchiidae: Epiplatinae) a new species of killifish from southwestern Guinea, West Africa. *Bonn zoological Bulletin* 57: 3–14
- Sonnenberg R, Nolte AW, Tautz D (2007) An evaluation of LSU rDNA D1–D2 sequences for their use in species identification. *Frontiers in Zoology* 4, 6: 12 pp.
- Sonnenberg R, Schunke AC (2010) On the taxonomic identity of *Fundulus beauforti* Ahl, 1924 (Cyprinodontiformes: Aplocheiloidei). *Zoosystematics and Evolution* 86: 337–341
- Sonnenberg R; Woeltjes T, Van der Zee JR (2011) Description of *Fenerbahce devosi* (Cyprinodontiformes: Nothobranchiidae), a new species of dwarf killifish from the eastern Congo Basin in the Democratic Republic of Congo. *Zootaxa* 2966: 1–12
- Swofford DL (1998) PAUP*. *Phylogenetic Analysis Using Parsimony (*and Other Methods)*. Version 4. Sinauer Associates, Sunderland, Massachusetts
- Tamura K, Dudley J, Nei M, Kumar S (2007) MEGA4: Molecular Evolutionary Genetics Analysis (MEGA) software version 4.0. *Molecular Biology and Evolution* 24: 1596–1599
- Teugels GG, Lévêque C, Paugy D, Traoré K (1988) État des connaissances sur la faune ichthyologique des bassins côtiers de Côte d'Ivoire et de l'ouest du Ghana. *Revue Hydrobiologie tropicale* 21: 221–237
- Thompson JD, Gibson TJ, Plewniak F, Jeanmougin F, Higgins DG (1997) ClustalX windows interface: flexible strategies for multiple sequence alignment aided by quality analysis tools. *Nucleic Acids Research* 24: 4876–4882
- Van der Zee JR (2002) Neue Einsichten in die Verwandtschaft der Gattung *Episemion*. *Deutsche Killifisch Gemeinschaft Journal* 34: 135–143
- Van der Zee JR & Sonnenberg R (2011) *Aphyosemion musafirii* (Cyprinodontiformes: Nothobranchiidae), a new species from the Tshopo Province in the Democratic Republic of Congo, with some notes on the *Aphyosemion* of the Congo Basin. *Bonn zoological Bulletin* 60: 73–87
- Vandersmissen, J-P (2003) Attention à une détermination trop hâtive à propos de *Roloffia* sp. l'engh Curoh. *Association Killiphile Francophone de Belgique, Killi-Contact* 30: 30–32

- Vandersmissen J-P, Etzel V, Berkenkamp HO (1980) Description de *Roloffia fredrodi* spec. nov., un nouveau Cyprinodontidae de Sierra Leone (Pisces, Cyprinodontidae). Association Killiphile Francophone de Belgique, Killi-Contact Separatum: 20 pp.
- Wildekamp RH (1993) A World of Killies. Atlas of the Oviparous Cyprinodontiform Fishes of the World. Volume 1. The American Killifish Association, Mishawaka, Indiana
- Wildekamp RH, Van der Zee JR (2003) Cyprinodontiformes. Pp. 298–442, in: Paugy D, Lévêque C, Teugels GG (eds) The Fresh and Brackish Water Fishes of West Africa. Volume II. IRD Éditions, Paris
- Wright F (1972) *Roloffia hastingsi*. British Killifish Association, Leaflet (83), 2 pp.
- Zhang D-X, Hewitt GM (1996) Nuclear integrations: challenges for mitochondrial DNA markers. Trends in Ecology and Evolution 11: 247–251